

# Werkzeugkatalog

tool catalogue

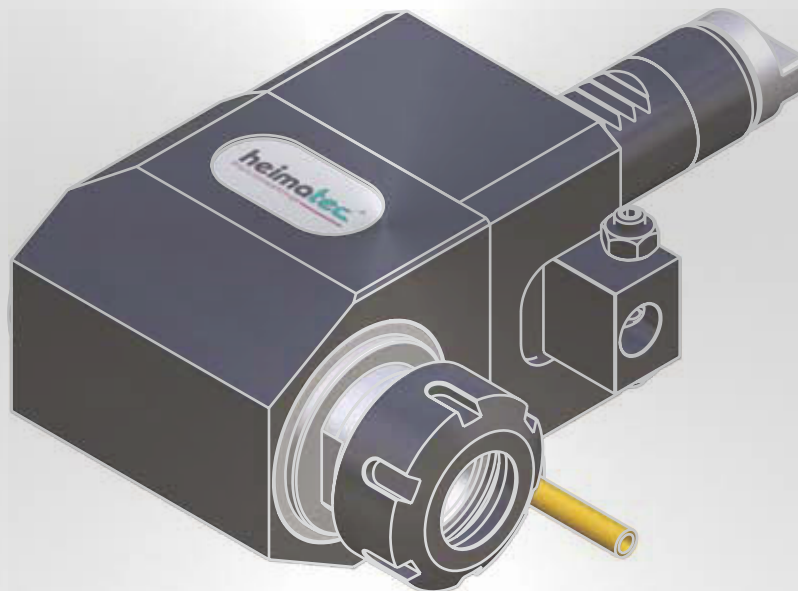

# SPINNER

TC 300 MC  
TC 300 MCY



Hinweis zu den AGBs:

Diese finden Sie in unserem Internetauftritt unter

[www.heimatec.de](http://www.heimatec.de)

Home/Impressum/AGB

Terms and conditions:

You will find them on our website

[www.heimatec.com](http://www.heimatec.com)

Home/Imprint/Terms and Conditions

Das Katalog-Werk einschließlich aller seiner Teile ist urheberrechtlich geschützt. Jede Verwertung außerhalb der engen Grenzen des Urheberrechtsgesetzes ist ohne Zustimmung der Rechteeinhaber unzulässig und strafbar. Das gilt insbesondere für Vervielfältigungen, Übersetzungen, Mikroverfilmungen und die Einspeicherung und Verarbeitung in elektronischen Systemen.

**heimatec® GmbH** behält sich Änderungen technischer Art jederzeit ohne Vorankündigung vor. Dies gilt insbesondere bei Anpassungen an neue oder geänderte internationale Normen oder bei Weiterentwicklungen unserer Produkte oder Herstellungsprozesse.

This catalogue, including all its parts, is protected by copyright. Each use outside the restricted limitations of the Copyright Act is inadmissible and liable to prosecution without the consent of heimatec. This is particularly valid for duplication, translation, microfilming and feeding and processing in electronic systems.

**heimatec® GmbH** reserves the right of technical changes everytime without advance notice, which is particularly valid for adaptations to new or changed international standards, or to developments of our products or manufacturing processes.

angetriebene Werkzeuge  
driven tools



**Axial-Bohr- und Fräskopf**  
axial drilling and milling head

$n_{max} = 8000 \text{ min}^{-1}$

8 010 25 098	ER 25 AX u-tec	EK	1:1
8 010 25 099	ER 25 AX u-tec	IK 25 bar	1:1
8 010 26 037	easy-quick HT 4	EK	1:1
8 010 26 038	easy-quick HT 4	IK 25 bar	1:1



**Axial-Bohr- und Fräskopf**  
axial drilling and milling head

Achsversatz / offset  $A=34,5$   
 $n_{max} = 16000 \text{ min}^{-1}$

8 016 24 005	ER 16 AX u-tec	EK	1:2
--------------	----------------	----	-----



**Winkel-Bohr- und Fräskopf**  
radial drilling and milling head

Mittenmaß / center distance  $H=75$

8 036 25 010	ER 25	EK	1:1
8 036 25 011	ER 25	IK 140 bar	1:1
8 036 26 004	easy-quick HT 4	EK	1:1
8 036 26 005	easy-quick HT 4	IK 140 bar	1:1
$n_{max} = 8000 \text{ min}^{-1}$			
8 036 24 016	ER 16 AX u-tec	EK	1:2
$n_{max} = 16000 \text{ min}^{-1}$			



**Schwenkkopf**  
universal head

Mittenmaß / center distance  $H=65$   
 $n_{max} = 8000 \text{ min}^{-1}$

8 040 24 042	ER 16	EK	1:1
--------------	-------	----	-----



**Mehrspindelbohrkopf**  
multi spindle drilling head

Achsversatz / offset  
 $n_{max} = 8000 \text{ min}^{-1}$

8 050 24 007	ER 16 AX u-tec	EK	1:1
--------------	----------------	----	-----



**Mehrspindel-Winkelbohrkopf**  
multi spindle radial head

Achsversatz / offset  
 $n_{max} = 8000 \text{ min}^{-1}$

8 053 24 005	ER 16 AX u-tec	EK	1:1
--------------	----------------	----	-----

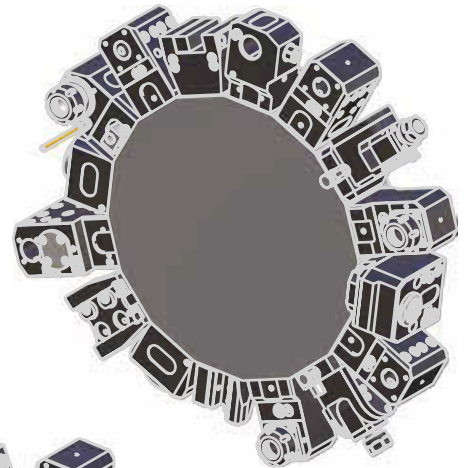

feste Werkzeuge  
static tool holders



**Werkzeughalter C1**  
tool holder C1

8 214 22 004	Vierkant/square 20/16	EK
--------------	-----------------------	----



**Werkzeughalter C3**  
tool holder C3

8 214 22 003	Vierkant/square 20/16	EK
--------------	-----------------------	----



**Kombi-Plandrehhalter**  
combi facing holder

8 234 24 004	Vierkant/square 20/16	EK
--------------	-----------------------	----

► Weitere Ausführungen auf Anfrage  
further versions on request

► Zubehör ZB...\*  
accessories ZB...\*

► easy-quick

► u-tec



**Bohrstangenhalter**  
boring bar holder

Mittenmaß / center distance H=75

8 230 26 011	ø20	IK/EK
8 230 27 024	ø25	IK/EK
8 230 28 017	ø32	IK/EK



**Doppel-Bohrstangenhalter**  
double boring bar holder

Mittenmaß / center distance H=70/105

8 253 27 008	2x ø25	IK/EK
--------------	--------	-------



**Spannzangenhalter**  
collet chuck holder

Mittenmaß / center distance H=75

8 236 25 000	ER 25	IK/EK
8 236 26 003	ER 32	IK/EK



**Aufnahmehalter**  
tool holder

Mittenmaß / center distance H=75

8 236 26 002	easy-quick HT 4	IK/EK
--------------	-----------------	-------



**Werkstoffanschlag**  
stock stop

Mittenmaß / center distance H=75

8 262 29 015		
--------------	--	--

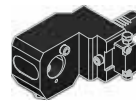

**Adapter für VDI**  
adapter for VDI

Mittenmaß / center distance H=75

8 209 22 012	DIN 69880 - 25	EK
--------------	----------------	----



**Abstechhalter**  
cut-off holder

höhenverstellbar / height adjustable

8 320 23 006	SH 32	EK
--------------	-------	----



**Verschlussstopfen Z2**  
plug Z2

8 200 20 001	25 K
8 200 20 004	25 S

▶ Weitere Ausführungen auf Anfrage  
further versions on request

▶ Zubehör ZB...\*  
accessories ZB...\*

▶ easy-quick

▶ u-tec

- ▶ **easy-quick HT Schnellwechselsystem**  
*easy-quick HT fast change system*

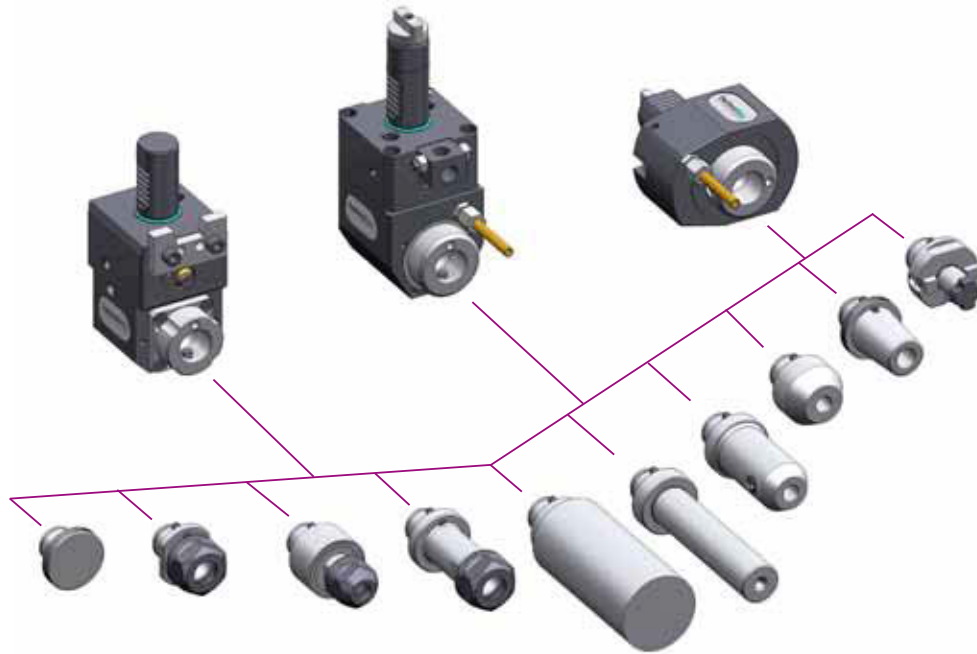

DAS Schnellwechselsystem von heimatec  
für angetriebene und feste Werkzeuge

*THE fast change system of heimatec  
for driven and static tools*

- ▶ Ausführungen siehe Katalog  
versions see catalogue

[www.heimatec.de](http://www.heimatec.de)  
Produkte / easy-quick

[www.heimatec.com](http://www.heimatec.com)  
products / easy-quick



- ▶ **u-tec<sup>®</sup> UT Wechselsystem**
- u-tec<sup>®</sup> UT change system**

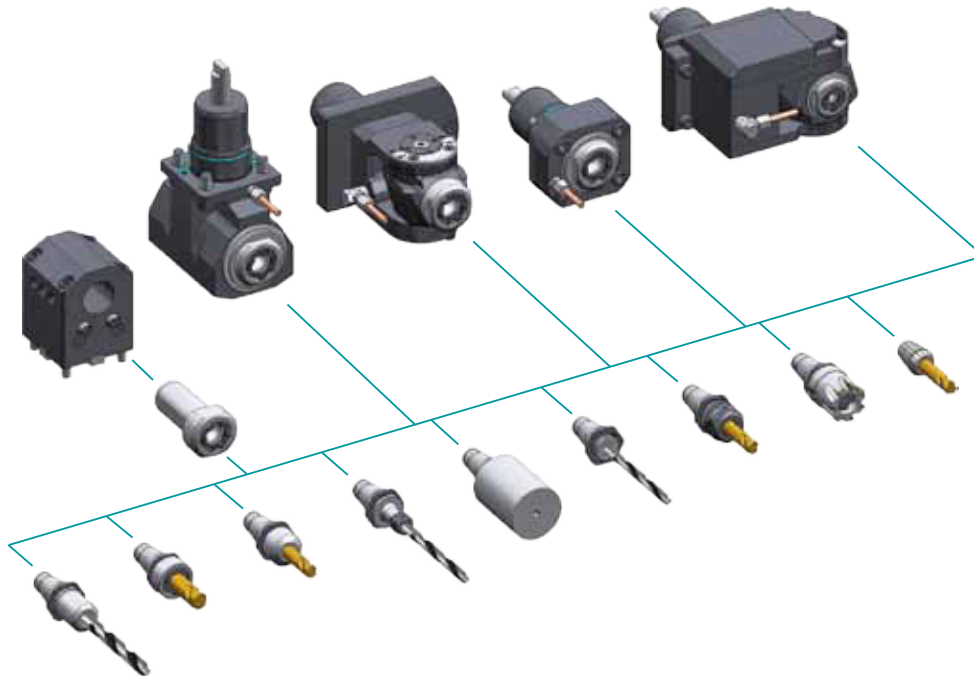

- ▶ Ausführungen siehe Katalog  
versions see catalogue

Unser Wechselsystem,  
das ALLES möglich macht

Our change system,  
that makes EVERYTHING possible



[www.heimatec.de](http://www.heimatec.de)  
Produkte / u-tec

[www.heimatec.com](http://www.heimatec.com)  
products / u-tec

► **Zubehör**  
**accessories**



► Ausführungen siehe Katalog  
versions see catalogue



[www.heimatec.de](http://www.heimatec.de)  
Produkte / Zubehör

[www.heimatec.com](http://www.heimatec.com)  
products / accessories

# heimatec®

- heimatec®-Niederlassungen  
*heimatec® overseas branches*
- unsere weltweiten Vertretungen  
*global representations of heimatec®*



## Hauptsitz/headquarters

heimatec® GmbH  
Präzisionswerkzeuge  
Carl-Benz-Straße 4  
D- 77871 Renchen  
Postfach 11 36  
D- 77867 Renchen  
Tel.: +49 (78 43) 94 66 0  
Fax: +49 (78 43) 94 66 66  
heimatec.de  
info@heimatec.de

heimatec® Inc.  
USA  
usa.heimatec.com  
USA@heimatec.com

heimatec®-Ost, JSC  
Russia  
ru.heimatec.com  
Russia@heimatec.com

heimatec® Ltd.  
Taiwan  
tw.heimatec.com  
Taiwan@heimatec.com

heimatec®  
Singapore  
sg.heimatec.com  
Singapore@heimatec.com